



## • T3-250 PL • T3-450 PL

250°C to 2500°C

### Features

- Two wire technology for easy electrical connection
- Wide temperature range 250°C....2500°C
- Spectral range 1.0 μm....1.6 μm
- Laser Light for precision targeting of the measuring object
- 10 ms response time adjustable upto 10 sec
- Analog output 2 wire....4-20 mA (Isolated)
- Digital TTL output & Infracsoft software
- Small spot sizes
- Emissivity can be adjusted directly at device
- Accessories for mounting and cooling options

### Standard Scope of Supply

- Pyrometer with 3 mtr. long connection cable
- Analog output 2 wire....4-20 mA
- Emissivity adjustable switch
- TTL output
- Calibration certificate, Operation manual

### Optional

- Extra cable lengths
- Mechanical and Electrical Accessories
- USB Interface card & PC Software

### Applications

- Induction Heating
- Casting
- Annealing
- Welding
- Forging
- Sintering
- Melting
- Rolling Mills
- Hardening

## • T3-250 PL • T3-450 PL

Highly Accurate On-Line Infrared Non-Contact Pyrometer in Two Wire Technology



T3-250 PL and T3-450 PL are specially designed IR Pyrometers of T3 Series family for non contact temperature measurement in demanding industrial environments. The Pyrometers are highly accurate and compact by nature with stainless steel housing to provide high operational safety for harsh industrial environments. The Pyrometers are designed for high temperature applications between 250°C....2500°C.

The parameters like Emissivity can be adjusted directly at device. Other parameter like Analog Sub Range, Response Time, Peak Picker, Valley Picker etc. can be preset ex-works or adjustable via Software Infracsoft. T3 Series is provided with TTL output. Using the USB interface Infraclink and Software pyrometer can be connected to PC for parameter setting and data logging.

### Software “Infracsoft”

AST “Infracsoft “ software is provided with Infraclink USB Interface accessory. It offers parameter setting, view real time graph, offline graph and to evaluate measuring data. Communication between the pyrometer and the software is implemented via USB dongle. It comes with record feature, spot size calculator and parameter settings features.

Some of the parameters adjustable via software are

- Response Time
- Picker
  - Peak
  - Valley
- Sub Range
- Unit of Temperature (°C/°F)



USB Interface

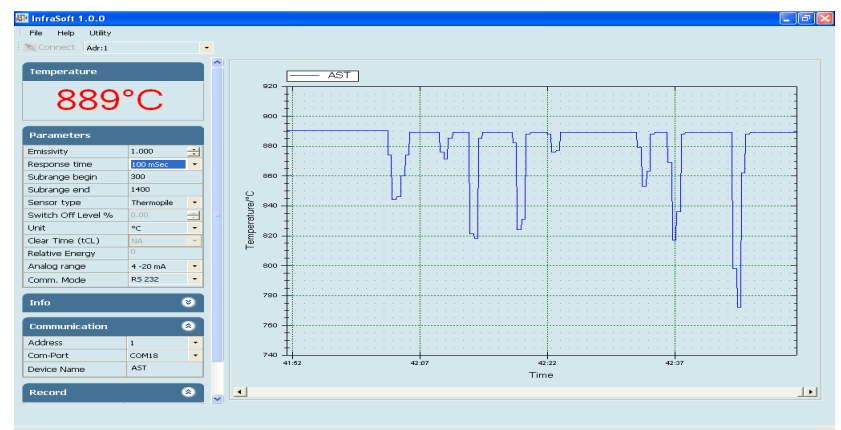

## Technical Specifications

Model	T3-250 PL	T3-450 PL
Temperature Range (Analog sub-range adjustable)	250°C....1300°C 300°C....1800°C 350°C....2500°C	600°C....2500°C
Spectral Range	1.6 μm	1.0 μm
Photodetector Type	InGaAs	Si
Distance to Spot Size Ratio	50:1 (250°C....1300°C) 100:1 (300°C....1800°C) 200:1 (350°C....2500°C)	200:1 (600°C....2500°C)
Emissivity (ε)	0.1....1.0 adjustable at device	
Response Time	10 msec adjustable upto 10 sec	
Accuracy	± 0.3% of the measured value + 1°C	
Repeatability	0.1% of reading in °C + 1°C	
Sighting Options	Laser Pilot Light (PL)	
Analog Output	2 wire....4-20mA, Linear Temperature Output Load : Max 500Ω at 24V DC, Max 200Ω at 18V DC	
Digital Output	TTL	
Operating Temp. Range	0°C.....70°C 0°C.....200°C (With water cooling jacket)	
Storage Temp. Range	-20°C...70°C	
Adjustable Parameters and Features via Software	Emissivity, Response Time, Analog Scale (Sub Range), Unit of Temperature (°C/°F), Peak Picker, Valley Picker	
Power Supply	24 V DC (5 to 25 V DC for Laser Targeting light (I≤30 mA))	
Power Consumption	For Laser Targeting Max 0.65 watt For Device Max 0.6 watt	
Laser Power	<1 m watt	
Protection Class	Ip65	
Housing	Stainless Steel	
Isolation	Analog output 2 wire... 4-20mA and measurement circuit is isolated against each other (2KVAC/1mA/60sec)	
Operating Humidity	10-95%, Non-Condensing Conditions	
Weight & Dimensions	250g Dia=∅40mm; Length=113.5mm	

We measure accurate temperature in extreme conditions

## Spot Sizes

Manufactured working distances WD (mm)	Spot Sizes(mm)			
	T3-250 250°C - 1300°C (50:1)	T3-250 300°C - 1800°C (100:1)	T3-250 350°C - 2500°C (200:1)	T3-450 600°C - 2500°C (200:1)
350	7	3.5	1.75	1.75
500	10	5	2.5	2.5
700	14	7	3.5	3.5
800	16	8	4	4
1000	20	10	5	5
1500	30	15	7.5	7.5
2000	40	20	10	10
2500	50	25	12.5	12.5
3000	60	30	15	15
5000	100	50	25	25
Aperture (A)	11	11	11	12

## Accessories

Water Cooling Jacket  
(Reference no. 8000-08)



Air Purge Unit  
(Reference no. 8700-01)



Mounting Clamp  
(Reference no: 8500-04)



Power supply Input 110/230V AC  
Reference No. 9000 - 02  
Output 24 V DC, 0.7Amp.



Temperature Indicator  
(Reference no: 9000-01)



We measure accurate temperature in extreme conditions

## Pyrometer Drawing

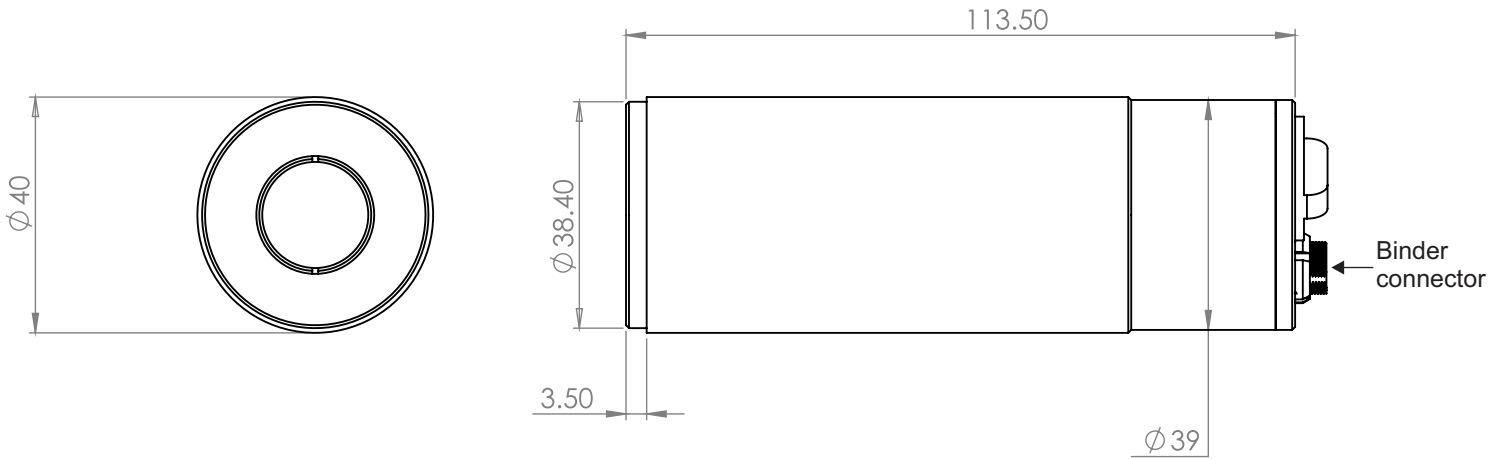

## Pyrometer Accessories Drawings

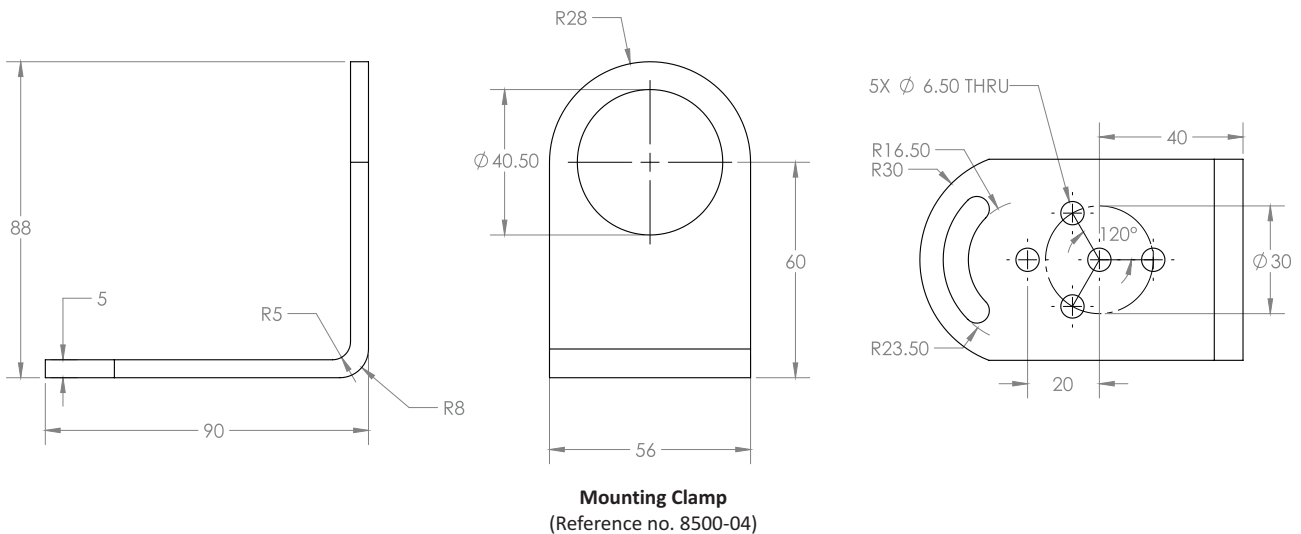
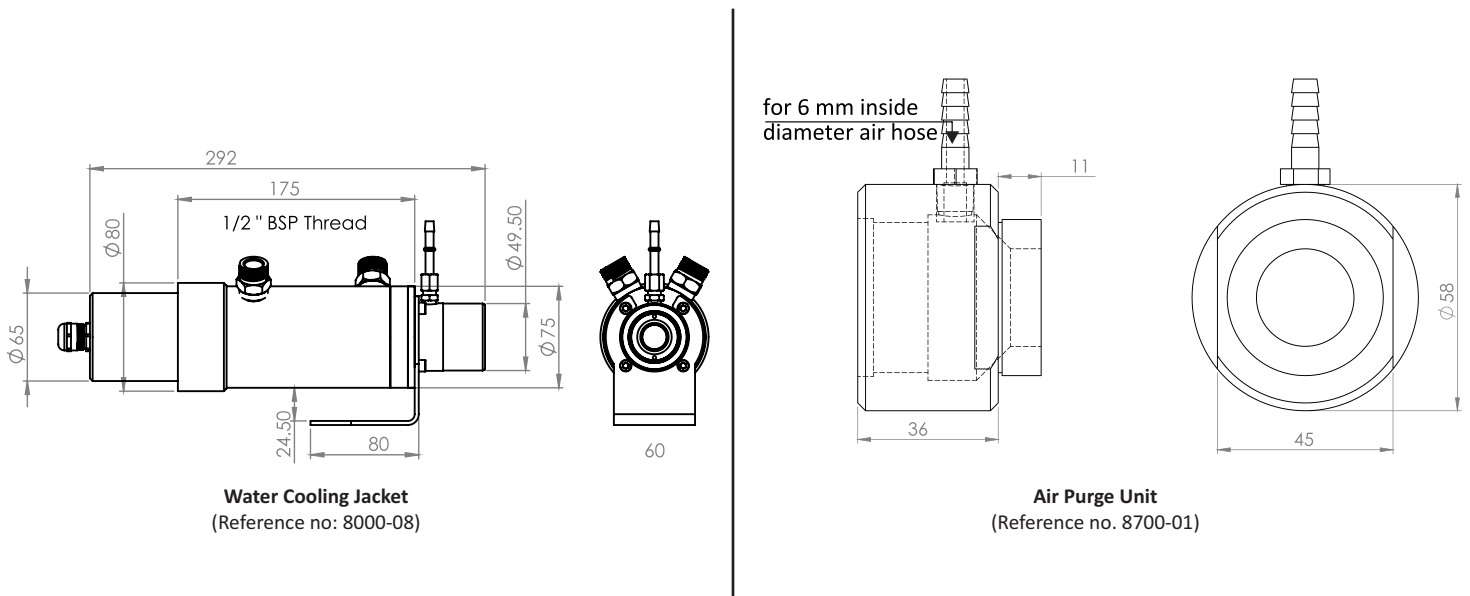

**Accurate Sensors Technologies Pvt. Ltd.**  
 Misgav Industrial Park, Misgav 20174 Israel  
 Phone : +972-4-9990025, Fax : +972-4-9990031  
 E-mail : info@accuratesensors.com

**Accurate Sensing Technologies Pvt. Ltd.**  
 188A, B-169 (Part), B-188 (A), Road No. - 5, M. I. A.,  
 Madri, Udaipur (Rajasthan) - 313003  
 Phone : +91-9352506032  
 Email : sales@astinfrared.com

**AST**  
 Accurate Sensors Technologies